

# Installation Instructions

## Surface Fixed

TUTTI  
Page 1 of 2

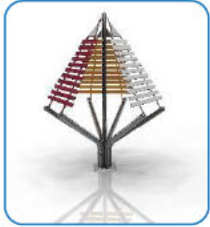

### Instrument Components:

M10 Nut



M6x20 Security Screw



M6 Saddle Strap

Metric Conversion:  
300mm/ 12"  
500mm/ 1ft 7 11/16"  
1555mm/ 61"  
1.5m/ 59"



Weight of heaviest part (TUTTI Frame)

1. Unpack frame 7no.

2. Lay packaging out on floor or assemble on non-abrasive surface to prevent marking of polished stainless steel.

3. Align Legs onto surface Plate, each leg should be numbered and corresponds with the number on the base plate. (See Assembly Guide Sheet)

4. Insert 6no. M8x60mm Screws into pre drilled holes in frame using TX40 bit.

5. Insert 6no. M10x20mm Screws into pre drilled holes in frame using TX45 bit to attach frame to surface base.

6. Attach 3No. Notes Panels to Frame and beater to each arm. (See Assembly Guide Sheet)

7. Locate Tutti in desired location and mark holes to fix to desired surface.

8. Fix Surface Plate to level surface using Coachscrews, Rawlbolts, chemical anchors or similar as deemed appropriate by Installer.

(It is your responsibility to ensure that the existing surface is suitable to receive the appropriate fixing)

9. Make sure all fixings are covered and secure using cover caps provided

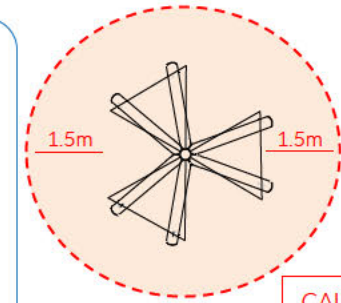

Install Instrument with 1.5m free space (from widest point) around it.

**CAUTION:** TUTTI surface can get hot in direct sunlight, if possible install in shaded areas.

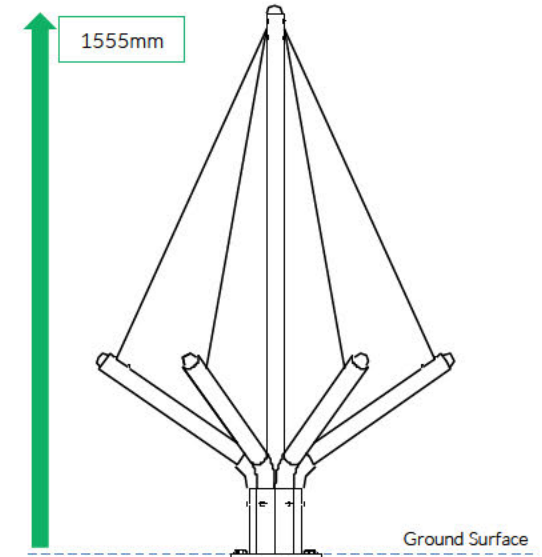

Surface Fix Components:



Pair Small Red Beaters X3



M8x60 Security Screw M10x20 Security Screw

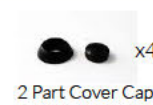

2 Part Cover Cap

Spares available from [percussionplay.com](http://percussionplay.com) or from your local distributor

55 Kg

# Assembly Guide PPTUTTI

Attach each Note Panel to the corresponding saddle straps on the Frame with the M6x20mm Screws provided



Surface Fixed  
TUTTI  
Page 2 of 2



**COMPONENTS LIST:**

-  Saddle Strap X9
-  M6x20 Pin torx X18
-  M8x60 Pin torx X6
-  M10x20 Pin torx X6

**Tools:**

-  x2  
TX 40 Driver Bit
-  x1  
TX 30 Driver Bit

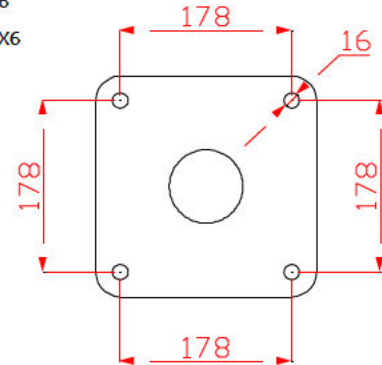

Attach one Red Beater to each of the arms to finish assembly.



Thread Lock Solution Required not supplied

Thread Lock Solution Required

- Components:**
-  x6  
M8x60 Security Screw
  -  x6  
M10x20 Security Screw