

Installation Instructions

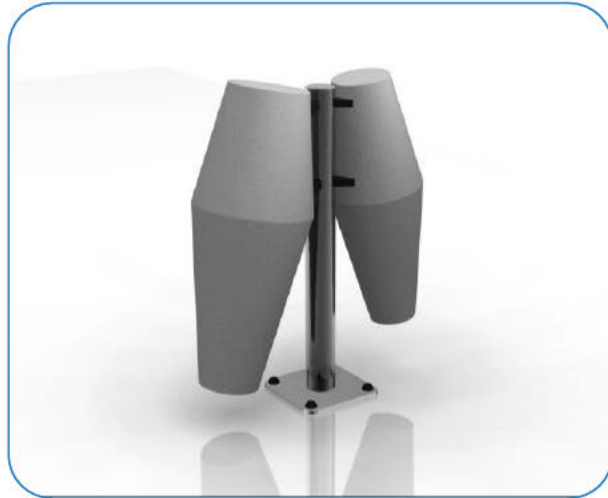

1. Attach the steel leg to each of the Tumbadoras with the M10x50 security screws, square washers and PU mounts. (1.1) (See Assembly Guide)

2. Attach Surface Fixing posts to legs (1.2) (See Ground Fix Post Installation Sheet)

3. Locate Plate in desired location and mark holes to fix to desired surface.

4. Fix to Surface using recommended ground anchors not supplied

5. Make sure all fixings are covered and secure using cover caps provided

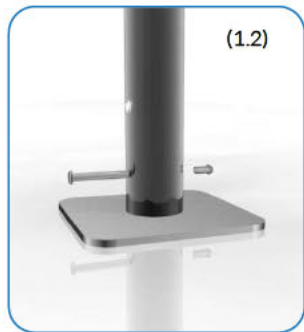
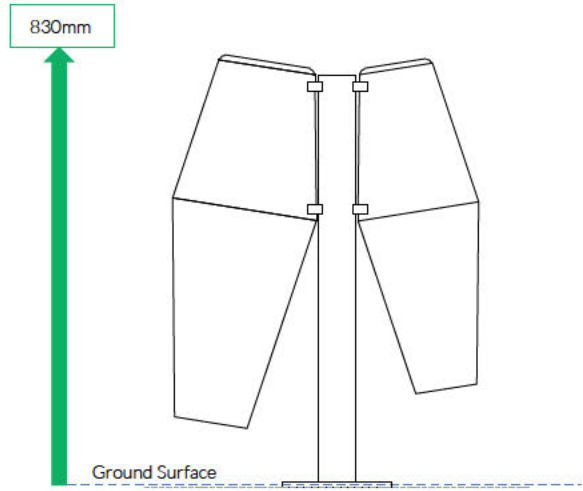
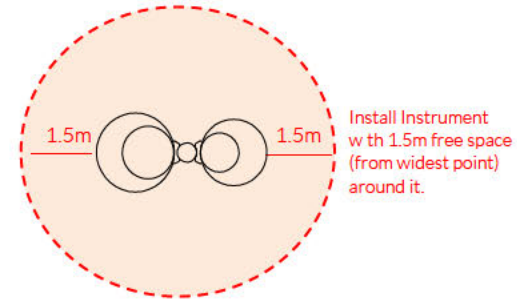





Surface Fixed

Tumbadoras
Page 1 of 3



Instrument Components:

-  x4
- M10x50 Security Screw
-  x4
- M10x50x3 Square washer
-  x2
- PU 200 Mount
-  x2
- PU 250 Mount



Metric
Conversion:
250mm/ 10"
400mm/ 16"
850mm/ 33"
1.5m/ 59"

Weight of heaviest part 16kg (Large Tumba Drum)



Played with hands

Surface Fix Components:

-  x1
- M10x70 Security Screw
-  x1
- M10 Barrel Nut
-  x4
- 2 Part Cover Cap

Ground Anchors not supplied

Spares available from percussionplay.com or from your local distributor

25 Kg

Tools:

 x1
TX 45 Driver Bit

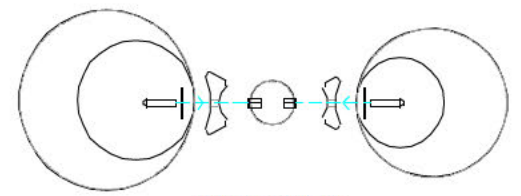
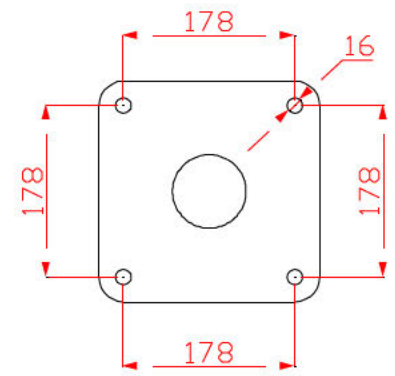

PPTUMB PLAN



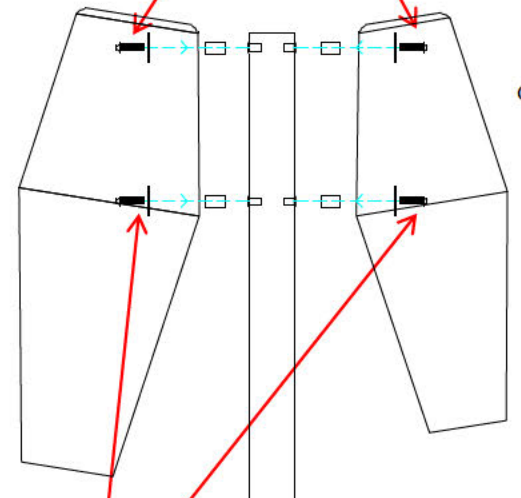



Thread Lock Solution
Required (Not Supplied)



Thread Lock Solution
Required (Not Supplied)

PPTUMB FRONT

COMPONENTS LIST:





-  M10x50 Pin torx X4
-  M10x50x3 square washer X4
-  PU MOUNT 200 X2
-  PU MOUNT 250 X2
-  M10x70 Pin torx X1
-  M10 Barrel Nut Pin torx X1

Ground Fixed

Tumbadoras
Page 2 of 3



Instrument Components:



-  x4
M10x50 Security Screw
-  x4
M10x50x3 Square washer
-  x2
PU 200 Mount
-  x2
PU 250 Mount

Thread Lock Solution
Required (Not Supplied)



 Played with hands

Surface Fix Components:

-  x1
-  x1
-  x4

Ground Anchors
not supplied

Spares available from
percussionplay.com or from your
local distributor

15 Kg

Tools:

 x2
TX 45 Driver Bit

Surface Fixed

Tumbadoras
Page 3 of 3



Components:



x1

M10 Barrel Nut



x1

M10x70 Secur ty Screw



x4

2 Part Cover Cap

Thread Lock Solution
Required (Not Supplied)

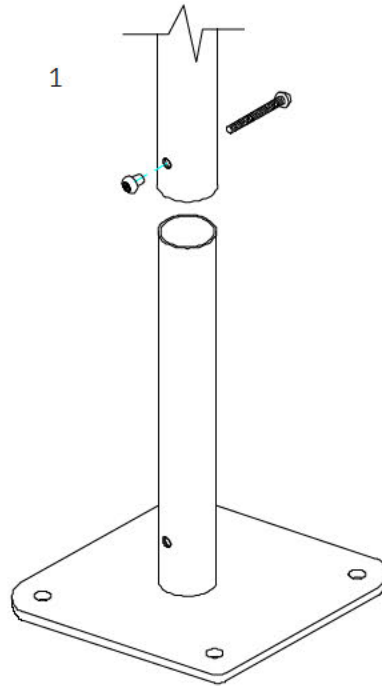

1
Locate the Surface fix Plate into the leg of the instrument.

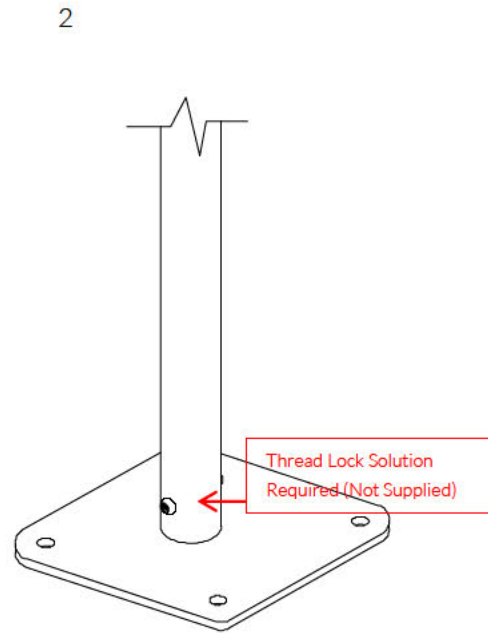

2
Fix instrument to Surface fix plate using M10 bolt and Barrel Nut and use **thread locking solution** to prevent fixings working loose.

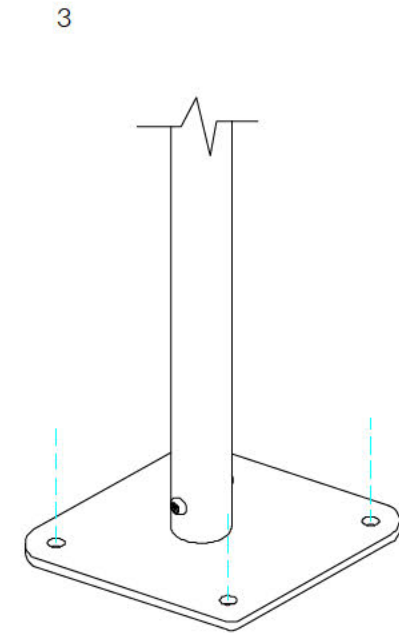

3
Fix Surface Plate to the ground surface **Ground Anchors Not provided** cover fixings with caps provided



MADE IN
BRITAIN

BSEN 1176