

Installation Instructions

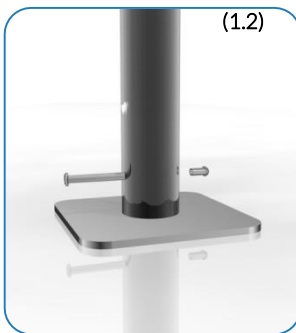
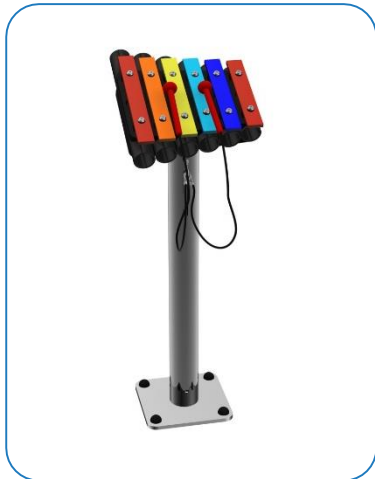

Weight of heaviest part 7kg (Metallophone)

1. Attach the steel legs to the base of the instrument with the M8 Nyloc Nuts and 2 part security caps. (1.1) (See Assembly Guide)

2. Attach Surface Fixing posts to legs (1.2) (See Ground Fix Post Installation Sheet)

3. Locate Plate in desired location and mark holes to fix to desired surface.

4. Fix to Surface using recommended ground anchors not supplied

5. Make sure all fixings are covered and secure using cover caps provided

6. Attach the 1 pair of beater to the saddle strap on the leg. (1.3)

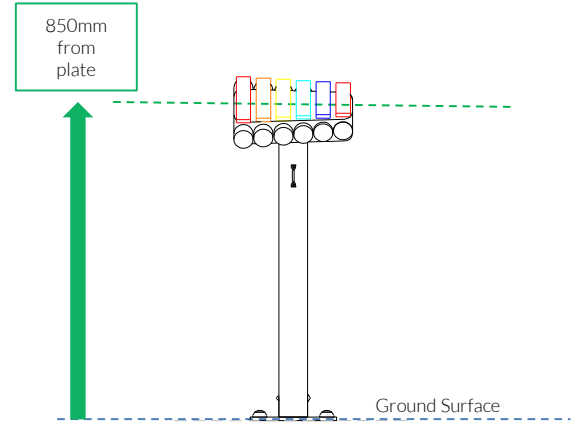
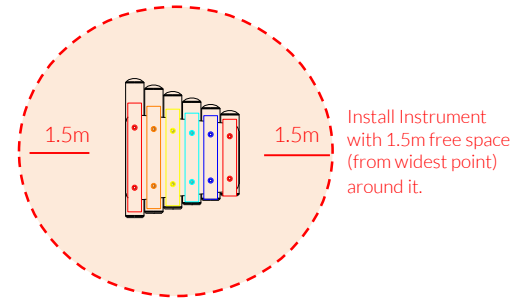

Surface Fixed
Rainbow Trio
Metallophone
Page 1 of 3





Instrument Components:

-  x4
M8 Nyloc Nut
-  x2
M6x20 Security Screw
-  x4
2 Part Cover Cap
-  x1
M6 Saddle Strap

Metric Conversion:
850mm/ 33"
1.5m/ 59"



Surface Fix Components:  x1

 x1  x4

Ground Anchors not supplied

Spares available from percussionplay.com or from your local distributor

19.5 Kg

Tools:

TX 30 Driver Bit x1 TX 40 Driver Bit x1

Surface Fixed
Rainbow Trio
Metallophone
Page 2 of 3



- Instrument Components:**
- x4
M8 Nyloc Nut
 - x2
M6x20 Security Screw
 - x4
2 Part Cover Cap
 - x1
M6 Saddle Strap

Thread Lock Solution
Required (Not Supplied)

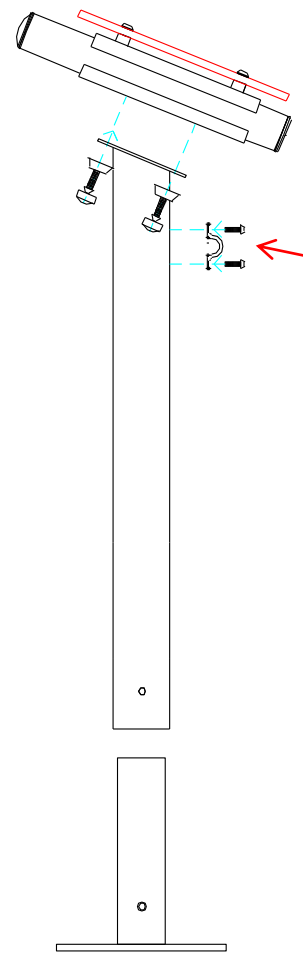

PPRMET SIDE

Thread Lock Solution
Required (Not Supplied)

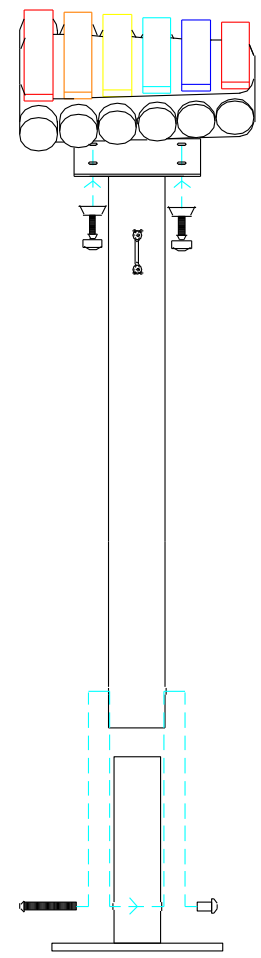

PPRMET FRONT

COMPONENTS LIST:

- 2 Part Cover Cap X8
- M8x20 Pin torx X4
- M10x70 Pin torx X1
- M10 Barrel Nut Pin torx X1
- Saddle Strap X1
- M6x20 Pin torx X2

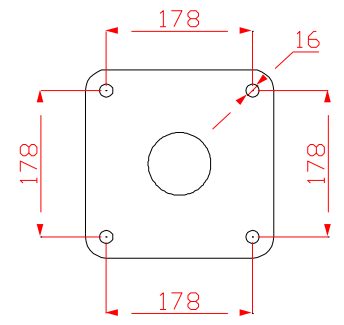

Pair Small Red Beaters X1

Surface Fix
Components:

- x1
- x1
- x4

Ground Anchors
not supplied

Spares available from
percussionplay.com or from your
local distributor

19.5 Kg

Tools:

 x2
TX 45 Driver Bit

Surface Fixed
Rainbow Trio
Metallophone
Page 3 of 3



Components:



x1

M10 Barrel Nut



x1

M10x70 Security Screw



x4

2 Part Cover Cap

Thread Lock Solution
Required (Not Supplied)

Metric
Conversion:
50mm/ 2"
250mm/ 10"
350mm/ 14"
400mm/ 16"
450mm/ 18"

1

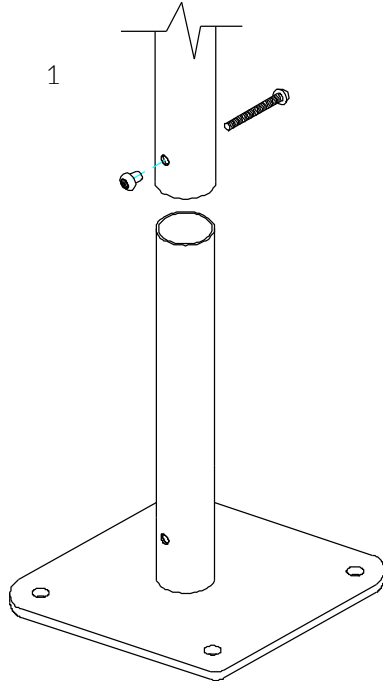

Locate the Surface fix
Plate into the leg of the
instrument.

2

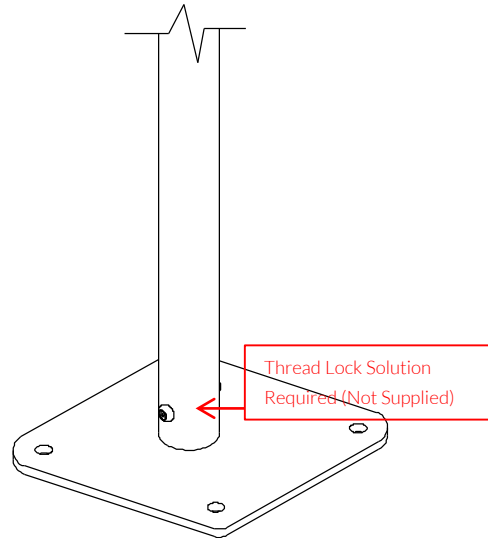

Fix instrument to Surface
fix plate using M10 bolt
and Barrel Nut and use
thread locking solution
to prevent fixings working
loose.

3

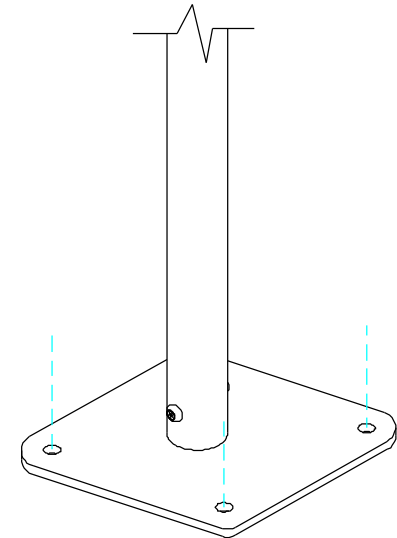

Fix Surface Plate to the
ground surface **Ground
Anchors Not provided**
cover fixings with caps
provided



MADE IN
BRITAIN

BSEN 1176

Installation Instructions

Surface Fixed

Rainbow Trio Chimes
Pentatonic 6 Notes
Page 1 of 3



1. Carefully lay 2 x legs on a level surface and check distance between legs is equal. Line up pre drilled holes in the backboards with the holes in legs and ensure the instrument is aligned square with the legs. Fix in place using M8x40mm screws supplied (see installation guide)

2. Attach Surface Fixing posts to legs (See Surface Fix Post Installation Sheet)

3. Locate Instrument in desired location and mark holes to fix to desired surface.

4. Fix Surface Plate to level surface using Coachscrews, Rawlbolts, chemical anchors or similar as deemed appropriate by Installer.

(It is your responsibility to ensure that the existing surface is suitable to receive the appropriate fixing)

5. Make sure all fixings are covered and secure using cover caps provided

6. Beaters can be fixed to Steel posts with fixings provided

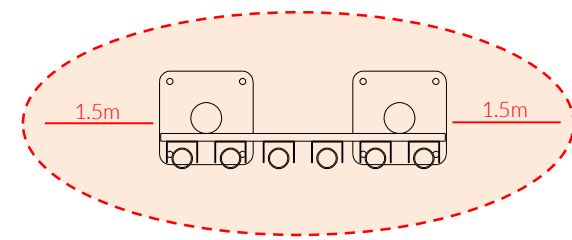

Install Instrument with 1.5m free space (from widest point) around it.

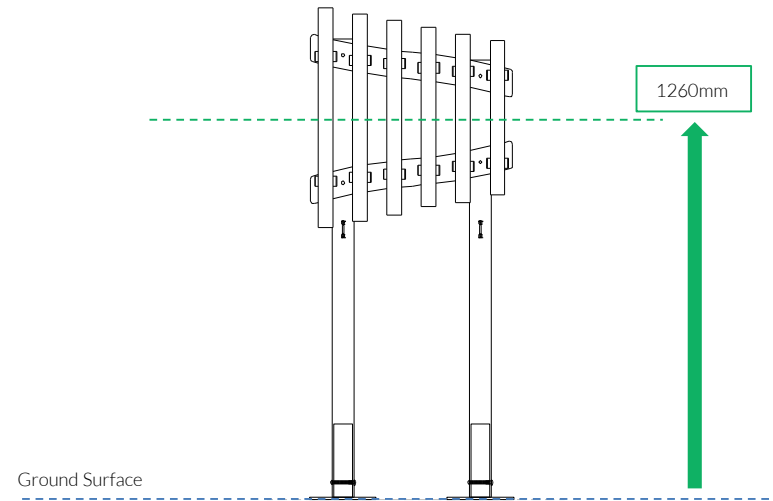

Weight of heaviest part 8.35kg (Freechimes)

Components:



Eye Straps X2



M6x20mm Secure Screw X4



M8x40mm Secure Screw X4

Metric Conversion:
1260mm/ 49 39/64"
1.5m/ 59"



Pair Small Beaters X1

Surface Fix Components:



2 Part Cover Cap x8



M10 Barrel Nut x2



M10x70 Security Screw x2

Spares available from percussionplay.com or from your local distributor

16 Kg

Tools:

TX 30 Driver Bit x1
TX 45 Driver Bit x2

Surface Fixed
Rainbow Trio Chimes
Pentatonic 6 Notes
Page 2 of 3



Components:

- Eye Straps X2
- M6x20mm Secure Screw X4
- M8x40mm Secure Screw X4

472mm Pentatonic 6 Note Post Centres

Thread Lock Solution Required (Not Supplied)

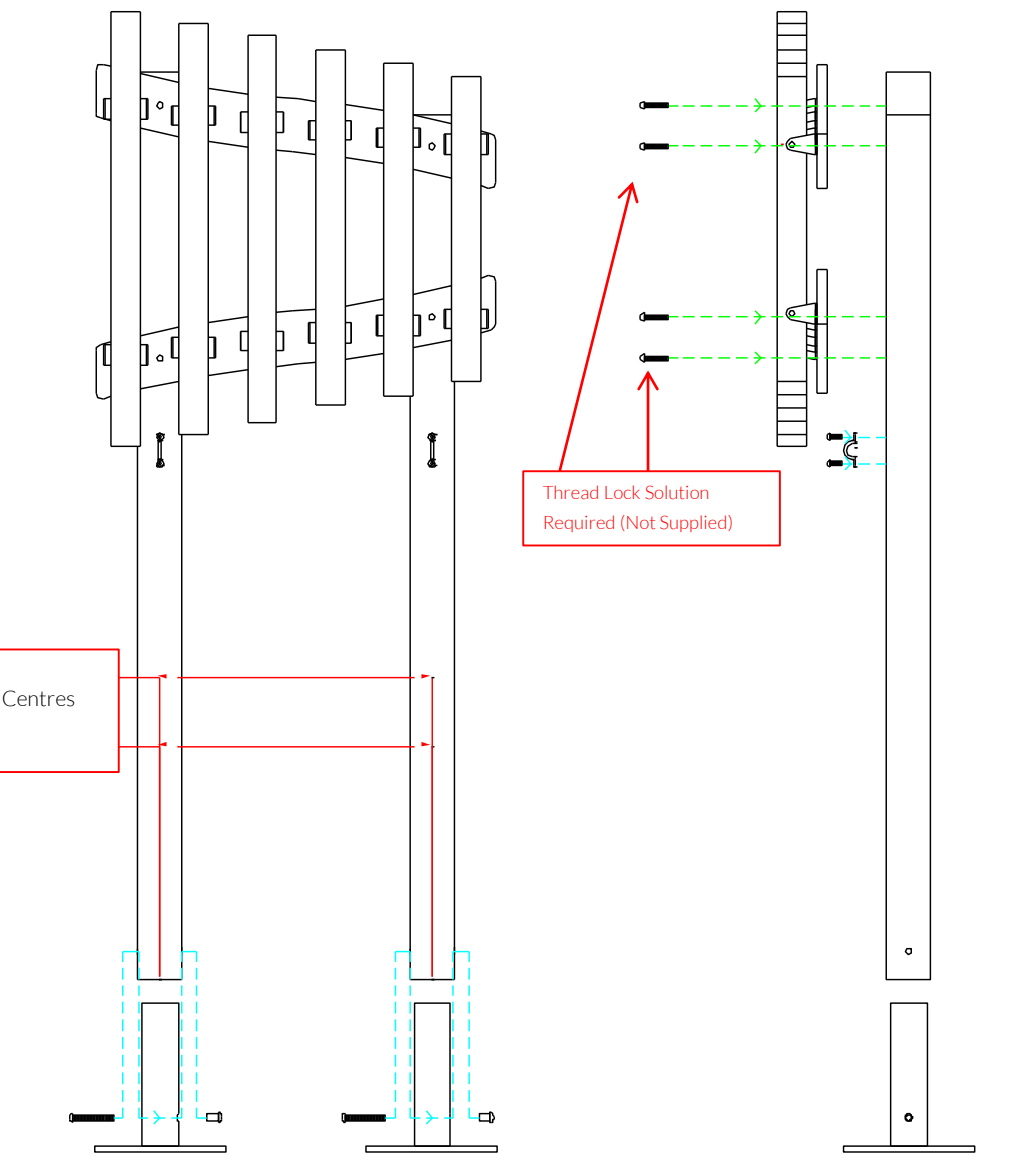

Thread Lock Solution Required (Not Supplied)

- COMPONENTS LIST:**
- Saddle Strap X2
 - M6x20 Pin torx X4
 - M8 X 40 Pin Torx X4
 - M10x70 Pin torx X2
 - M10 Barrel Nut Pin torx X2

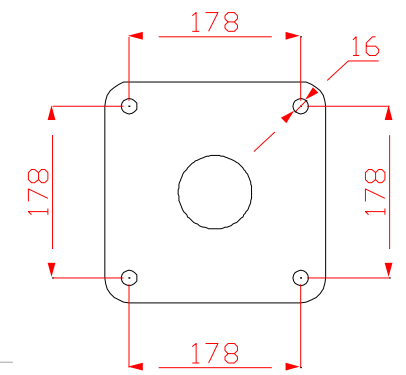

Pair Small Beaters X1

Surface Fix Components:

- 2 Part Cover Cap x8
- M10 Barrel Nut x2
- M10x70 Security Screw x2

Spares available from percussionplay.com or from your local distributor

16 Kg

Tools:

 x2
TX 45 Driver Bit

Surface Fixed
Rainbow Trio Chimes
Pentatonic 6 Notes
Page 2 of 3



Components:



x2

M10 Barrel Nut



x2

M10x70 Security Screw



x8

2 Part Cover Cap

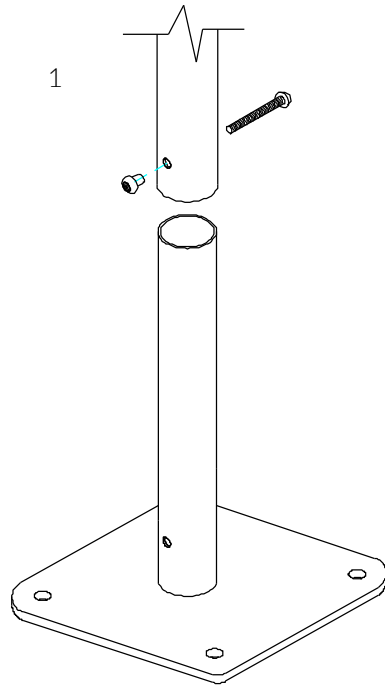

1
Locate the Surface fix Plate into the leg of the instrument.

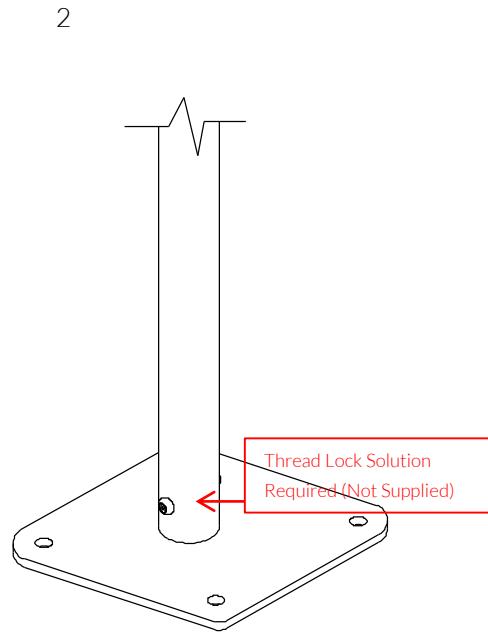

2
Fix instrument to Surface fix plate using M10 bolt and Barrel Nut and use **thread locking solution** to prevent fixings working loose.

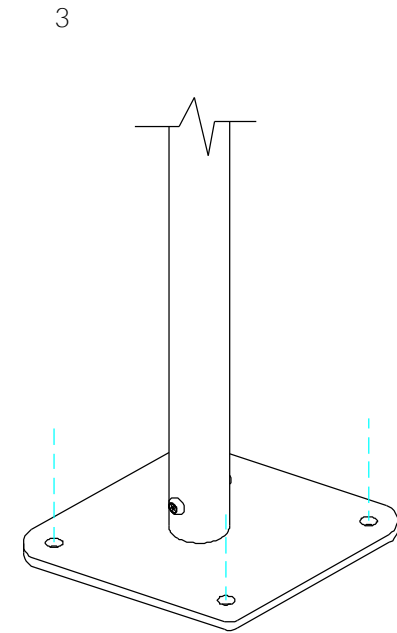

3
Fix Surface Plate to the ground surface **Ground Anchors Not provided** cover fixings with caps provided

Thread Lock Solution
Required (Not Supplied)



MADE IN BRITAIN

BSEN 1176

Installation Instructions

Surface Fixed

Rainbow Bongos
1 of 2



Instrument Components:



x6

M10x50 Security Screw



x6

M10x50x3 Square washer



x4

PU 200 Mount



x2

PU 250 Mount

Metric Conversion:
250mm/ 10"
850mm/ 33"
1.5m/ 59"

Weight of heaviest part 7 kg (bongos)

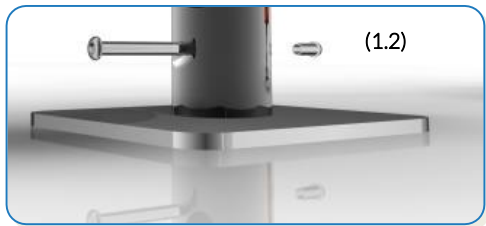
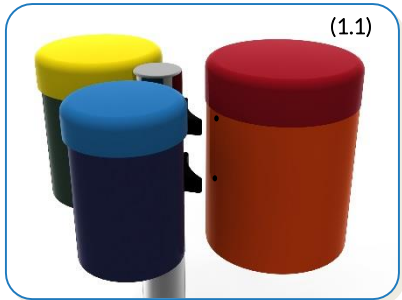

1. Attach the steel leg to each of the congas with the M10x50 security screws, square washers and PU mounts. (1.1) (See Assembly Guide)

2. Attach Surface Fixing posts to legs (1.2) (See Ground Fix Post Installation Sheet)

3. Locate Plate in desired location and mark holes to fix to desired surface.

4. Fix to Surface using recommended ground anchors not supplied

5. Make sure all fixings are covered and secure using cover caps provided

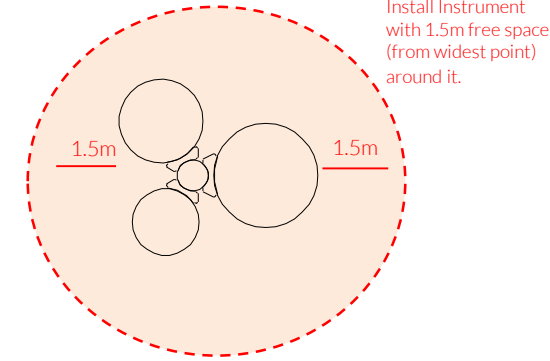

850mm
from Plate

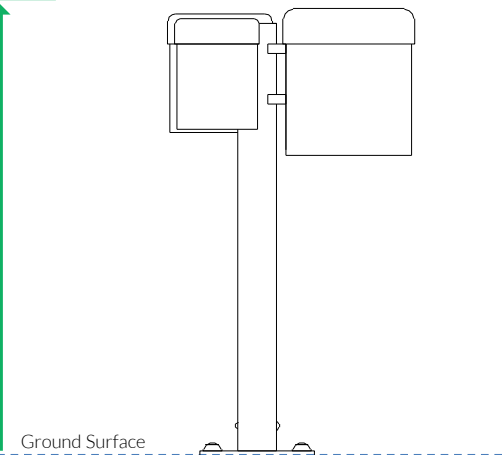

Surface Fix Components:



x1



x1



x4

Ground Anchors not supplied

Spares available from percussionplay.com or from your local distributor

15 Kg





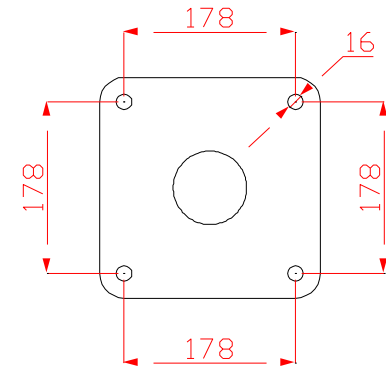

Tools:



x2
TX 45 Driver Bit



COMPONENTS LIST:

-  M10x50 Pin torx X6
-  M10x50x3 square washer X6
-  HDPE MOUNT 200 X4
-  HDPE MOUNT 250 X2
-  2 Part Cover Cap X4
-  M10x70 Pin torx X1
-  M10 Barrel Nut Pin torx X1



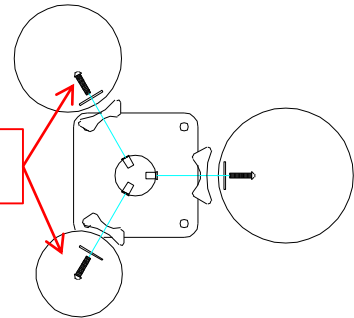

Thread Lock Solution
Required (Not Supplied)



Surface Fixed
Rainbow Bongos
2 of 2



Instrument
Components:

-  x6
M10x50 Security Screw
-  x6
M10x50x3 Square washer
-  x4
PU 200 Mount
-  x2

Thread Lock Solution
Required (Not Supplied)

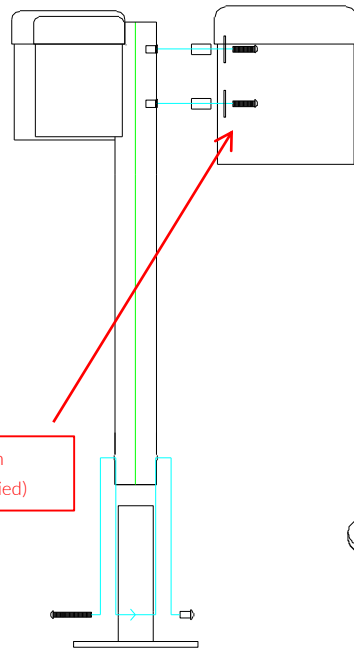

PPRTBON FRONT

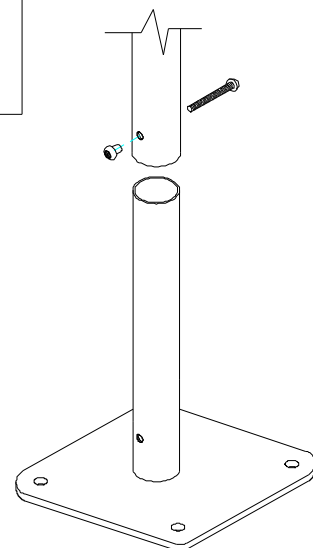

Locate the Surface fix
Plate into the leg of the
instrument.

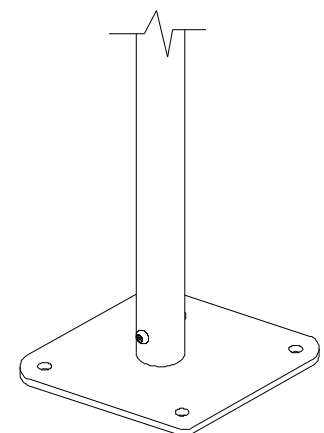

Fix instrument to Surface
fix plate using M10 bolt
and Barrel Nut and use
thread locking solution
to prevent fixings working
loose.

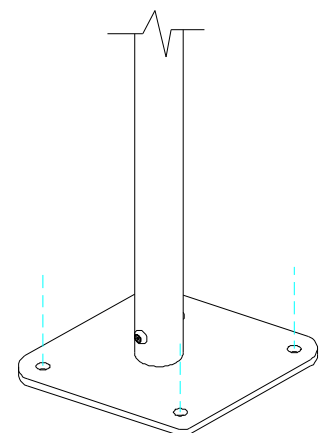



Fix Surface Plate to the
ground surface **Ground
Anchors Not provided**
cover fixings with caps
provided



Played with hands

Surface Fix
Components:

-  x1
-  x1
-  x4

Ground Anchors
not supplied

Spares available from
percussionplay.com or from your
local distributor

15 Kg