

# Installation Instructions

## Surface Fixed

Freechimes  
Alto/ Soprano  
Page 1 of 3



Weight of heaviest part **8.35kg** (Freechimes)

**1. Carefully lay 2 x legs** on a **level surface** and check distance between **legs is equal**. Line up pre drilled holes in the backboards with the holes in legs and ensure the instrument is aligned square with the legs. **Fix** in place using **M8x40mm screws** supplied (see installation guide)

**2. Attach Surface Fixing posts** to legs (**See Surface Fix Post Installation Sheet**)

**3. Locate Instrument** in desired location and mark holes to fix to desired surface.

**4. Fix Surface Plate** to level surface using Coachscrews, Rawlbolts, chemical anchors or similar as deemed appropriate by Installer.

(It is your responsibility to ensure that the existing surface is suitable to receive the appropriate fixing)

**5. Make sure all fixings** are covered and secure using cover caps provided

**6. Beaters can be fixed** to Steel posts with fixings provided

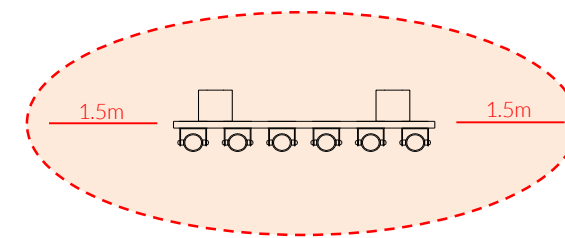

Install Instrument with 1.5m free space (from widest point) around it.

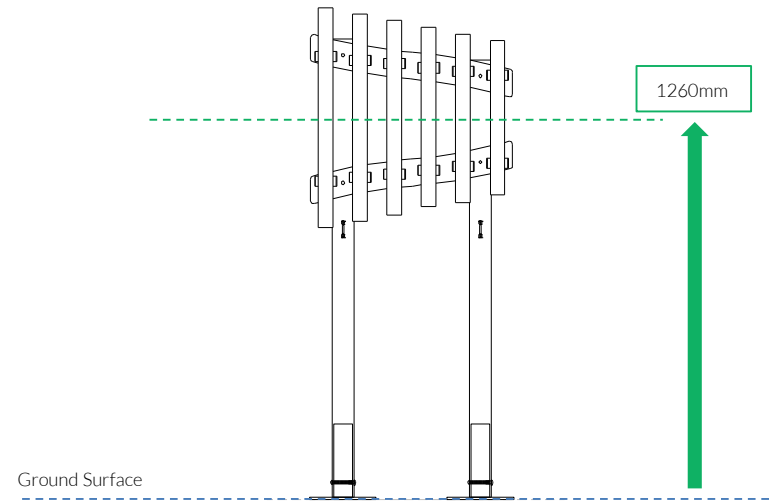

### Components:



Metric Conversion:  
1260mm/ 49 39/64"  
1.5m/ 59"



Pair Small Beaters X1



Surface Fix Components:





Spares available from [percussionplay.com](http://percussionplay.com) or from your local distributor

16 Kg

**Tools:**

 x1  
 x2  

TX 30 Driver Bit    TX 45 Driver Bit

- COMPONENTS LIST:**
-  Saddle Strap X2
  -  M6x20 Pin torx X4
  -  M8x40 Pin Torx X4
  -  M10x70 Pin torx X2
  -  M10 Barrel Nut Pin torx X2

## Surface Fixed



Freechimes  
Alto/ Soprano  
Page 2 of 3



### Components:

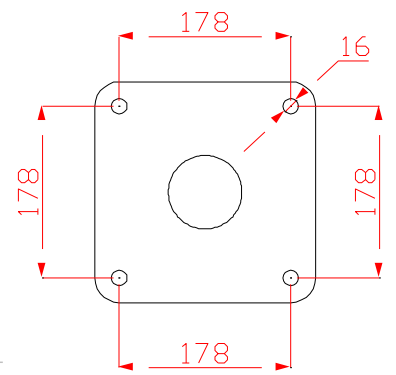
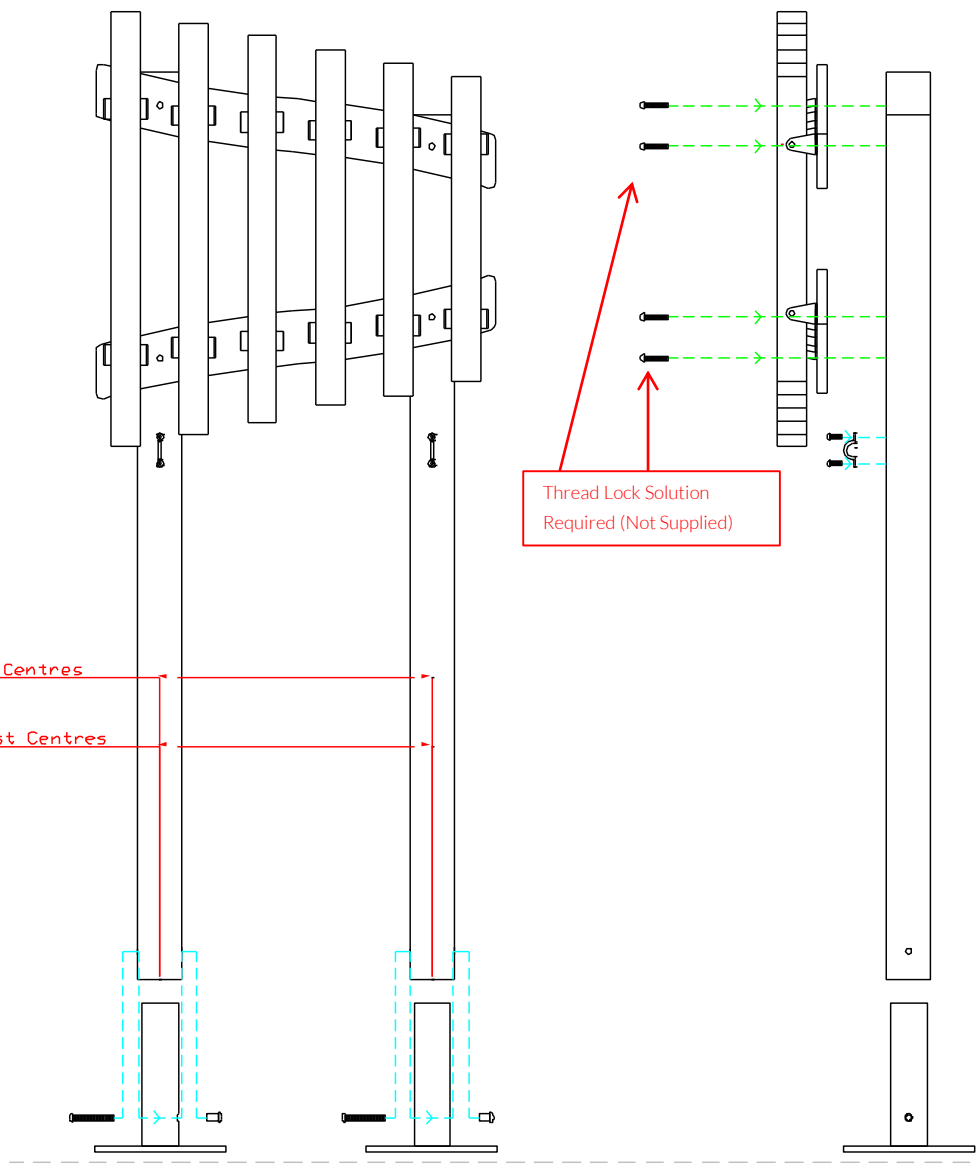
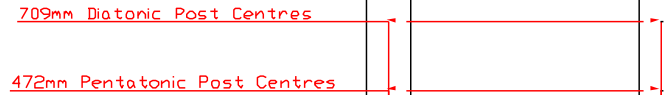

-  Eye Straps X2
-  M6x20mm Secure Screw X4
-  M8x40mm Secure Screw X4

Thread Lock Solution  
Required (Not Supplied)

Pair Small Beaters X1

Surface Fix Components:

-  x8
-  x2
-  x2

Spares available from [percussionplay.com](http://percussionplay.com) or from your local distributor

**16 Kg**

Tools:

 x2  
 TX 45 Driver Bit

## Surface Fixed

Freechimes  
 Alto/ Soprano  
 Page 3 of 3



## Components:

 x2

M10 Barrel Nut

 x2

M10x70 Security Screw

 x8

2 Part Cover Cap

Thread Lock Solution  
 Required (Not Supplied)



MADE IN  
BRITAIN

BSEN 1176

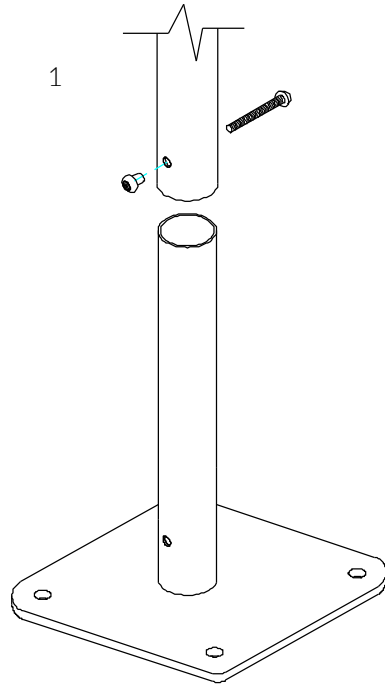

Locate the Surface fix  
 Plate into the leg of the  
 instrument.

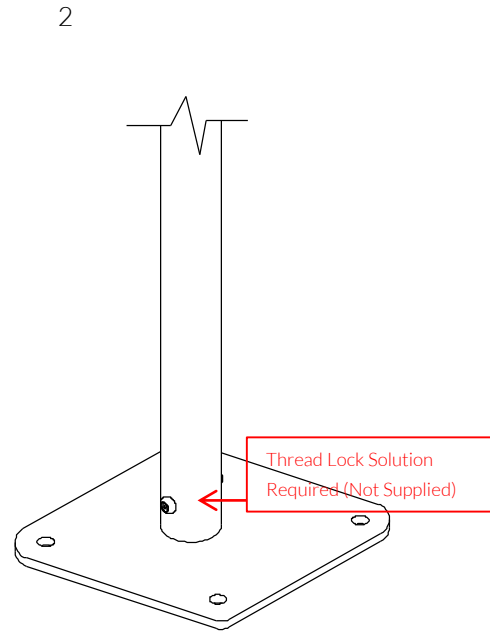

Fix instrument to Surface  
 fix plate using M10 bolt  
 and Barrel Nut and use  
**thread locking solution**  
 to prevent fixings working  
 loose.

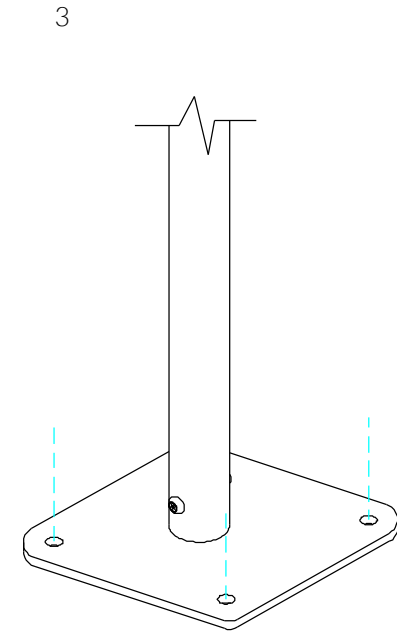

Fix Surface Plate to the  
 ground surface **Ground  
 Anchors Not provided**  
 cover fixings with caps  
 provided