

# Ground Fix Installation

## Surface Fixed

Cyclone  
Page 1 of 2



### Components:



x1

M8x25 Security Screw



x1

M8 Shakeproof Washer

**1.** Lay post on non-abrasive surface. Unscrew M6x20 security screws and remove curved cover plate to expose internal fixings.

**2.** Push the M8 shakeproof washer onto the M8x25 screw (threadlocker pre-applied).

**3.** Locate the hole for the bearing, insert and brace. Screw the M8x25 screw tightly into the bearing within the post.

**4.** Rotate the wheel and check there is no lateral movement, confirming the wheel is fastened securely.

**5.** Re-fix the curved cover plate with its two M6x20 screws.

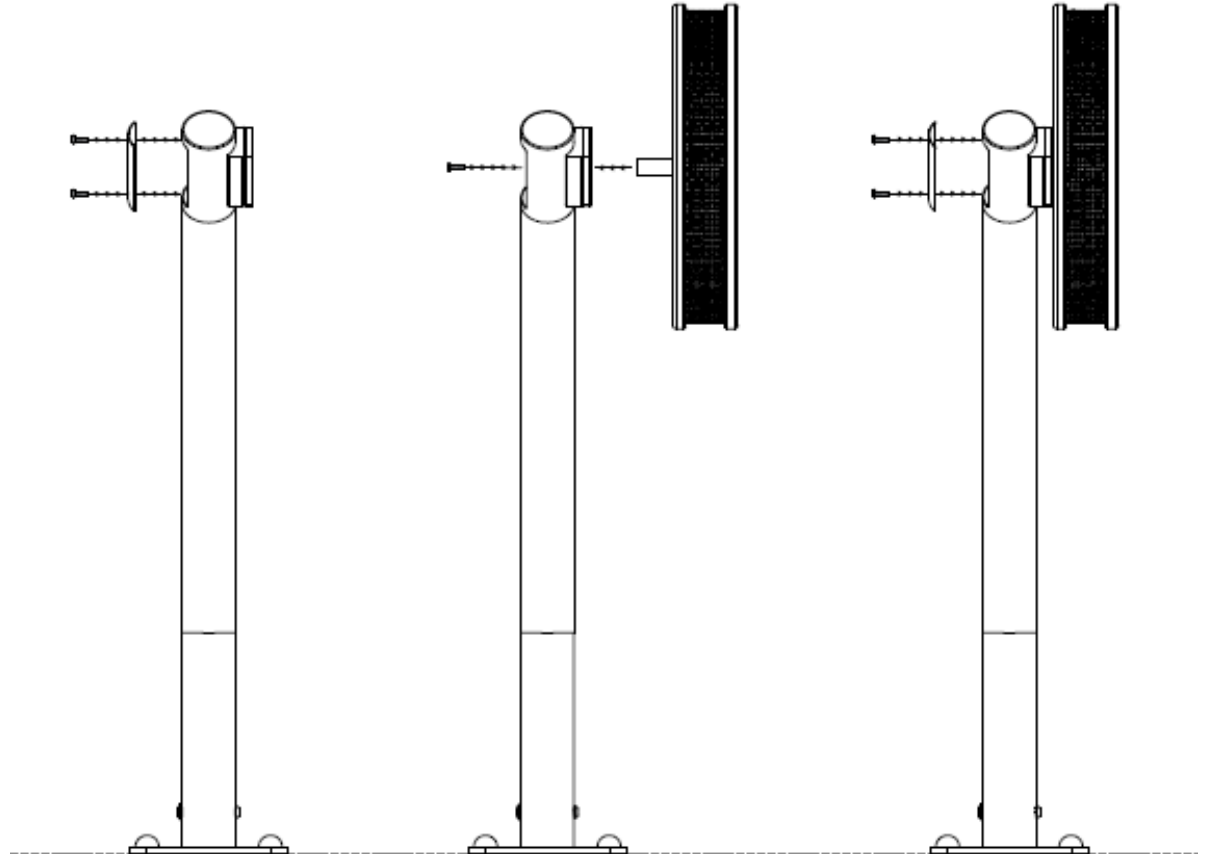

Played with hands

Ground Anchors  
not supplied



Spares available from  
[percussionplay.com](http://percussionplay.com) or from your  
local distributor

22 Kg

# Installation Instructions

Install Instrument with 1.5m free space (from widest point) around it.

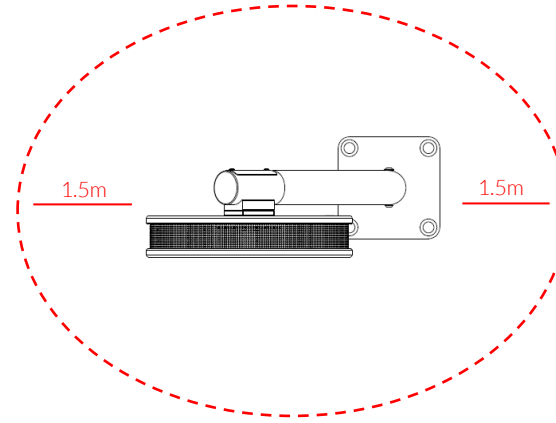

1. Determine a suitable location and **clear an area 3m around** the desired spot for installation.

2. Sheath post over surface plate stanchion and secure with M10 Bolt and Barrel nut.

3. Secure plate to ground with recommended ground fix anchors (not supplied), and cover exposed tops with cover caps.

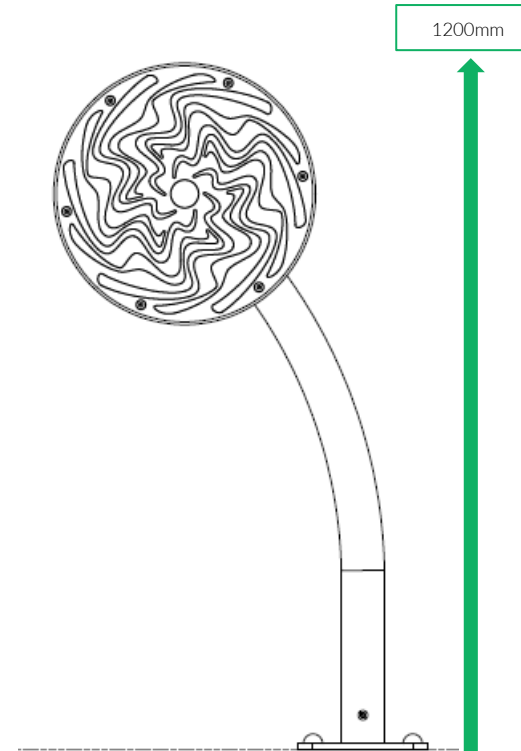

1200mm

## Surface Fixed

Cyclone  
Page 2 of 2



### Components:



x1

M8x25 Security Screw



x1

M8 Shakeproof Washer



Played with hands

Ground Anchors  
not supplied



Spares available from  
[percussionplay.com](http://percussionplay.com) or from your  
local distributor

22 Kg